

USING COMPONENTS OF THE DENSACLAD™/DENSOPOL™ BITUMEN TAPE & MASTIC SYSTEM

USE:

This guide is intended to demonstrate the best way to wrap a steel or cast iron valve using The Densoclad™ or Densopol™ Bitumen Tape & Mastic System. This system comprises a surface primer Denso Primer D™, followed by Densyl™ Mastic or Denso™ Profiling Mastic, which is used to fill the voids and smooth the contours prior to overwrapping with Densoclad™ or Densopol™ Bitumen Tape.

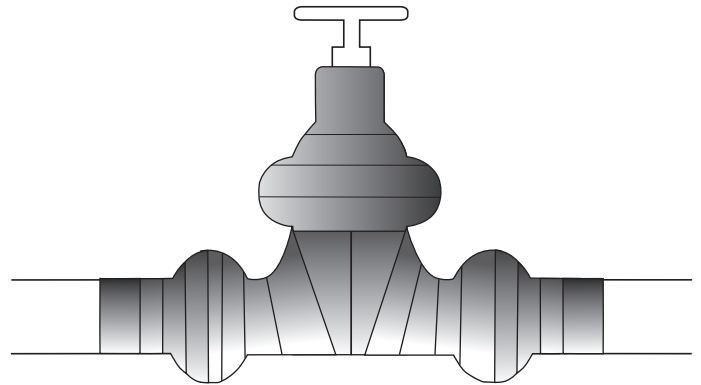

Because the shapes and sizes of valves vary, the illustrations are not drawn to scale and are intended to be used for reference only.

METHOD

Fig. 1. The valve shall be cleaned so that it is free of loose dirt and grease. Heavy corrosion may be removed by power tool method. Denso Primer D™ shall be applied to the entire surface to be protected.

Fig. 3. The first wrap. The chosen Denso™ tape shall be measured, cut and applied to the valve according to Fig 3. The numerical sequence shown in Fig 3 shall be followed. These tape pieces are positioned around the bottom of the valve to form a 'U' shape. The tape shall be applied to form a double layer over the centre of the valve body.

The number of tape pieces used in this stage shall be adjusted in accordance with the width of the tape used and the size of the valve.

Additional tape pieces shall be spirally wrapped around the valve top. The wrapping shall start below the valve shoulder and shall cover the ends of the vertical tape pieces to secure them in place. The wrapping shall continue in a weatherboard fashion, upwards towards the top of the valve.

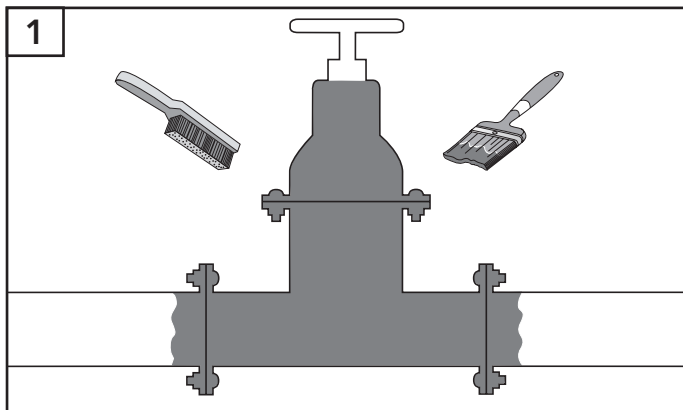
Ensure the tape does not interfere with the movement of the valve wheel or mechanism. Smooth down the tape and its edges to remove air and form a seal.

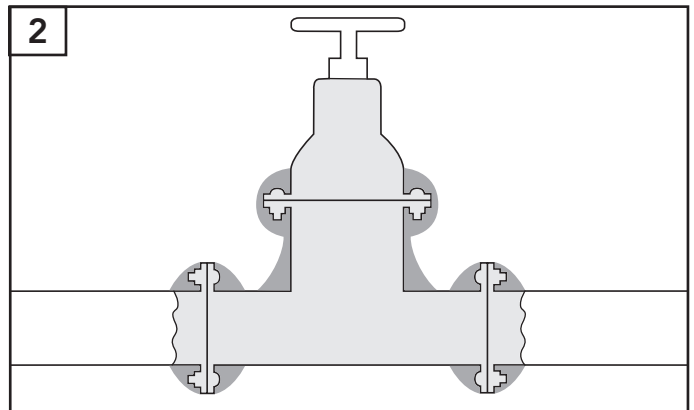
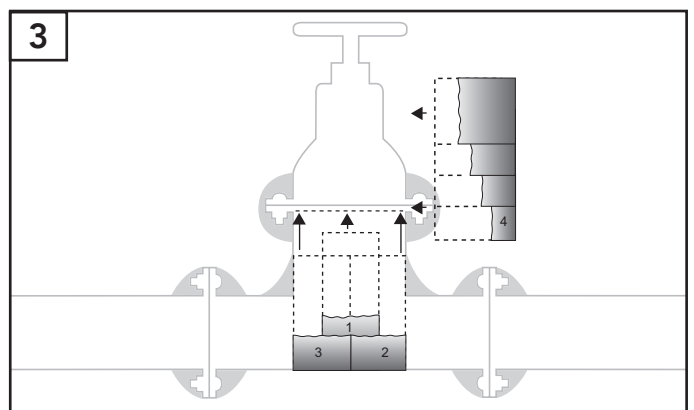

Fig. 2. All flanges, faces and fittings on the valve shall be profiled with Densyl Mastic or Denso Profiling Mastic to facilitate easy wrapping of subsequent tape layers. The profiling shall be built up in layers to prevent the creation of voids and ensure there are no acute angles.



METHOD - Continued overleaf...

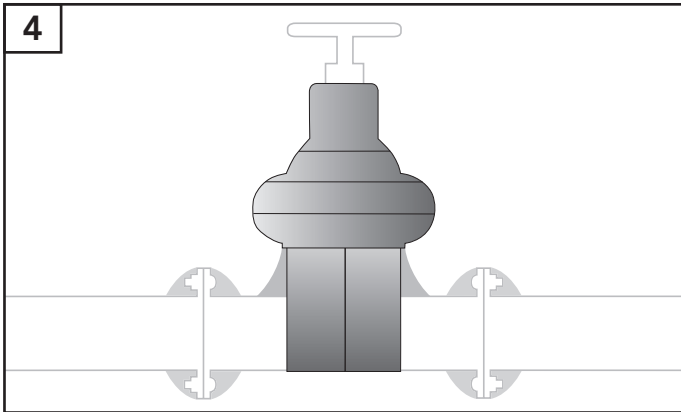

Fig. 4. The completed first /

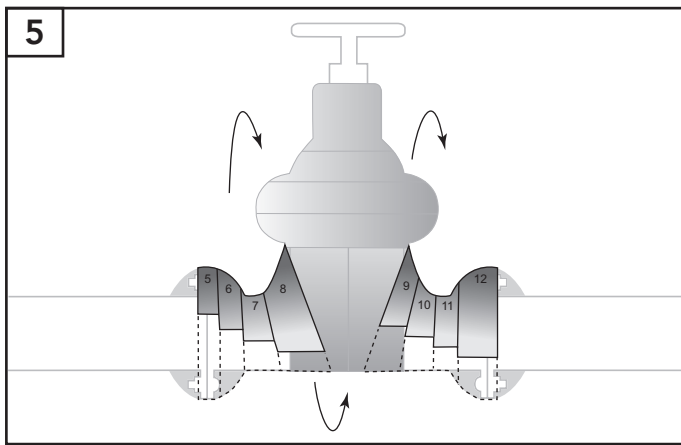

Fig. 5. The second wrap. The wrapping shall start at one of the valve flanges and shall progress towards the valve body, starting with a double circumferential wrap before progressing at a 55% overlap to give a double layer. When the tape applied in the First Wrap is reached the tape being applied shall be taken across the centre of the valve and the spiral wrapping shall continue on the other side of the valve working towards the opposite flange. The numbers in Fig 5 refer to the approximate number of spiral wraps. The tape shall be smoothed down and to remove air and form a seal. The number of circumferential wraps used in this stage shall be adjusted in accordance with the width of the tape and the size of the valve.

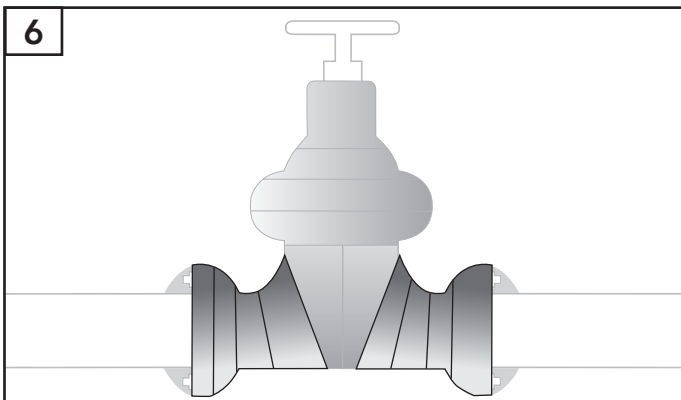

Fig. 6. / second /

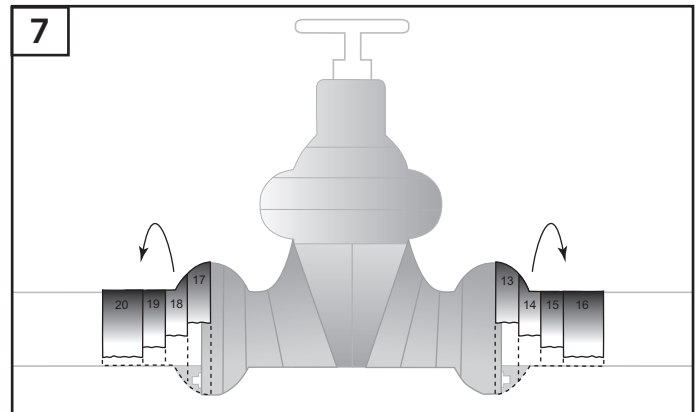
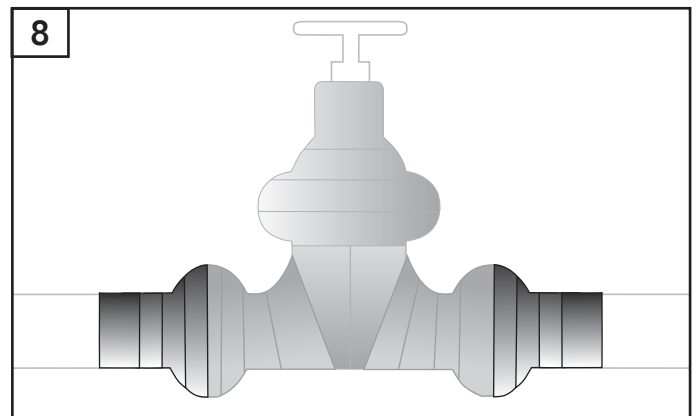

Fig. 7. The third wrap. The wrapping shall start at one of the valve flanges and shall progress away from the valve body, starting with a double circumferential wrap before progressing at a 55% overlap to give a double layer. The wrapping shall overlap onto the tape from the Second Wrap. This application shall be repeated on the other valve flange to complete the wrapping, starting with a double circumferential wrap before progressing at a 55% overlap to give a double layer.

Fig. 8. / third wrap.



Tape Outerwraps: If an extra Denso outerwrap is specified for mechanical protection purposes, it shall be applied in an identical manner as shown for the DensoPol or DensoClad Tape. Take particular care to apply adequate tension whilst wrapping to remove air and seal all of the tape edges.

Disposal: Please minimise or avoid waste wherever possible. Please do not discard waste material, including packaging, in the surrounding environment. Follow all relevant legislation for disposal.

Important: Winn & Coales (Denso) Ltd pursue a policy to develop and continually improve all of our products and therefore information given in this data sheet is intended as a general guide and does not constitute a warranty, specification or risk assessment. These guidelines may not cover all circumstances; however, our sales personnel are committed to assisting the user in establishing the suitability of the product for its intended purpose and additional specific information, including Safety Data Sheets, is available on request. We recommend that installation is carried out with due regard to Health and Safety and in accordance with relevant local statutes and regulations. Any conflict between these guidelines and the specific project specifications must be resolved by the user before work commences. All rights reserved.