



DENSOSTRIP™



**DENSOSTRIP™**

OPTIMAL SEALING FOR PRECAST CONCRETE UNITS

SUITABLE FOR:

- Box Culverts
- Manholes
- Inspection Chambers
- Shafts
- Tunnels
- Pipe Sections



# DENSOSTRIP™

**DENSOSTRIP™ IS DESIGNED TO PROVIDE A PERMANENTLY FLEXIBLE, WATERTIGHT JOINT BETWEEN PRECAST CONCRETE UNITS.**

These joints are formed under compression when the compound is reduced to half its original thickness. Densostrip is easy to apply by hand and ensures an effective long-term seal under all site and weather conditions.

## SYSTEM FEATURES:

- Permanently flexible watertight seal
- Meets BS EN 1917 requirements for manholes (no need for concrete surrounds)
- One easy to use grade for all weather conditions
- Fast drying primer
- Supplied in appropriate profiles for every type of joint
- Approved and meets government requirements
- Manufactured in the UK - professional technical advisory service
- Resistant to chemical and biological attack

## APPROVALS

Densostrip is specifically approved as a joint sealant for precast concrete units manufactured to BS EN 1917.

- BS EN 1917:2002 Concrete manholes and inspection chambers
- CESWI Civil Engineering Specification for the Water Industry 7th Edition (UKWIR Ltd)
- Sewers for Adoption, 5th Edition (WRc plc)



APPLICATION OF DENSOSTRIP TO A BOX CULVERT



A MANHOLE AFTER DENSOSTRIP APPLICATION



DENSOSTRIP IS RESISTANT TO WATER AND SEA WATER



DENSOSTRIP USED FOR SEALING CONCRETE UNITS ON BERTHS



# DENSOSTRIP™ SIZE GUIDE

For circular manholes, inspection chambers and access shafts with Ogee, Rebated or Tongued and Grooved Joints

## BOX CULVERT JOINTS

Densostrip Size	25mm x 40mm (unless otherwise specified by the concrete unit manufacturer)
Densostrip Length (per joint)	Formula = (2 x height) + (2 x width)
Densostrip Primer	5 litres per 60m

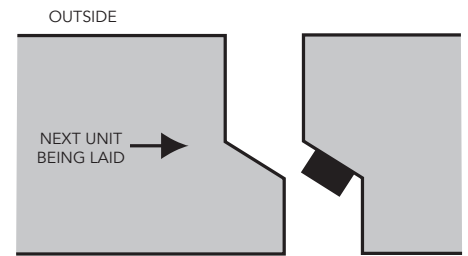

## TONGUE AND GROOVED MANHOLE JOINTS

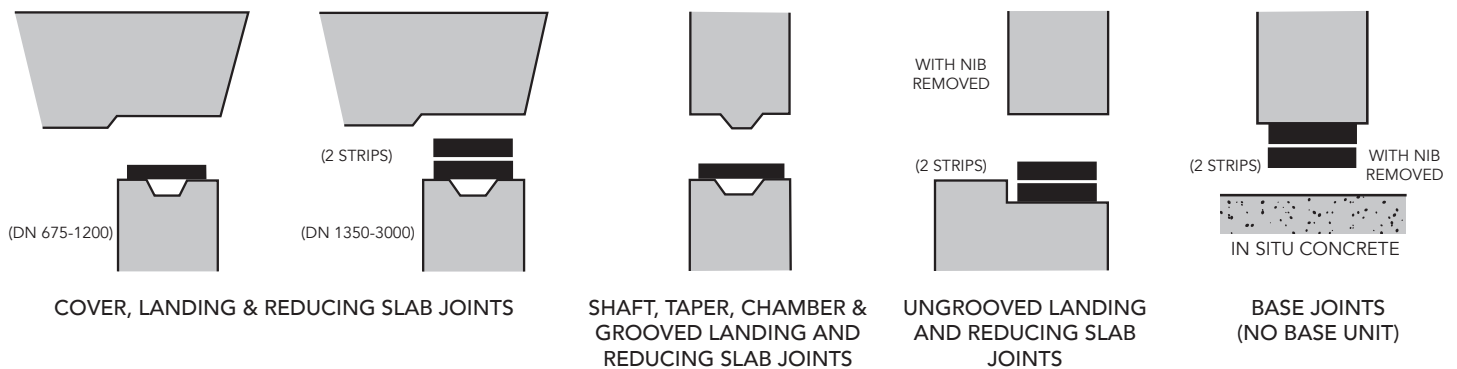

Densostrip Size	12mm x 25mm		12mm x 60mm		12mm x 80mm				12mm x 120mm			
Unit Nom. Size (DN)	675	750	900	1050	1200	1350	1500	1800	2100	2400	2700	3000
Densostrip Length	2.5m	3m	3.5m	4m	4.5m	5m	5.5m	6.5m	7.5m	8.5m	9.5m	10.5
Densostrip Primer	5 litres per 75m				5 litres per 50m				5 litres per 35m			

## OGEE OR REBATED MANHOLE JOINTS

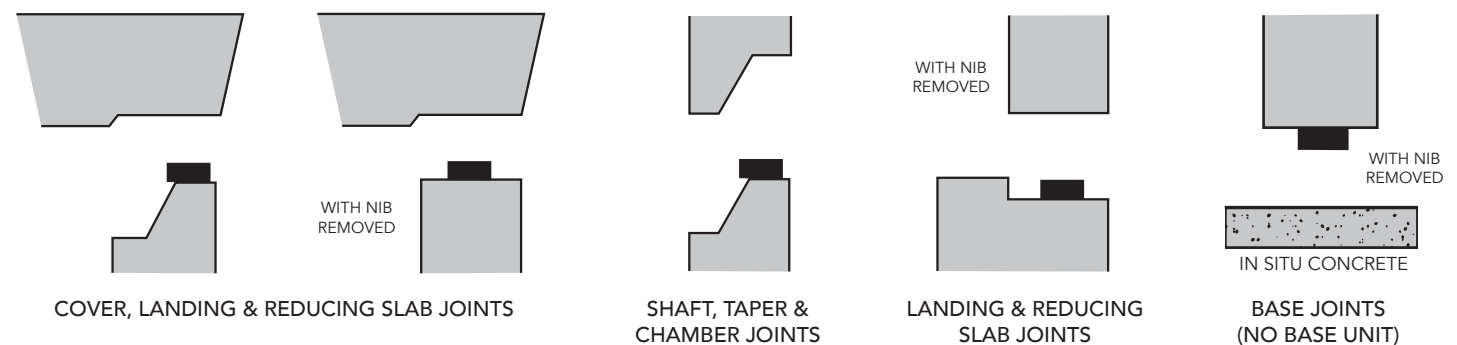

Densostrip Size	12mm x 25mm		20mm x 25mm		22mm x 30mm				25mm x 40mm			
Unit Nom. Size (DN)	675	750	900	1050	1200	1350	1500	1800	2100	2400	2700	3000
Densostrip Length (per joint)	2.5m	3m	3.5m	4m	4.5m	5m	5.5m	6.5m	7.5m	8.5m	9.5m	10.5
Densostrip Primer	5 litres per 120m				5 litres per 90m				5 litres per 60m			



DENSOSTRIP USED TO SEAL BURIED PRECAST CONCRETE TRENCHES DELIVERING SERVICES TO A HISTORIC WATER FOUNTAIN (LEFT)



FOR FURTHER PROTECTION OF EXTERNAL BOX CULVERT JOINTS FROM BACKFILL INFILTRATION OR AREAS WITH HIGH WATER TABLES...

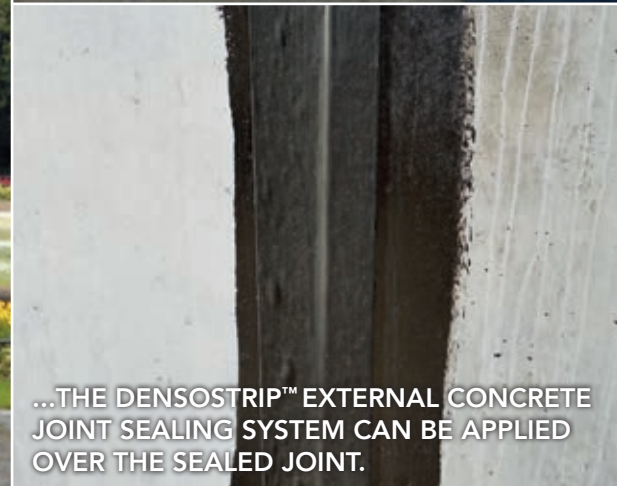

...THE DENSOSTRIP™ EXTERNAL CONCRETE JOINT SEALING SYSTEM CAN BE APPLIED OVER THE SEALED JOINT.

## PACKING DETAILS

Densostrip Size	12 x 60	12 x 80	12 x 120	12 x 25	20 x 25	22 x 30	25 x 40
Densostrip Length (per carton)	4 x 6m	3 x 6m	2 x 6m	9 x 6m	6 x 5m	5 x 4.5m	4 x 4m
Densostrip Primer	5 litre and 25 litre cans						

# DENSOSTRIP™

PUB No. 452.07.2019



FM 01548 | EMS 583748  
ISO 9001:2015 & ISO 14001:2015

## WINN & COALES (DENSO) LTD

TEL: +44 (0) 208 670 7511  
FAX: +44 (0) 208 761 2456  
EMAIL: mail@denso.net  
WEB: www.denso.net

Winn & Coales (Denso) Ltd  
33 - 35 Chapel Road  
London SE27 0TR  
UNITED KINGDOM



A MEMBER OF WINN & COALES INTERNATIONAL